



**YOUR
PARTNER IN
Clean™**



KÄRCHER SUMMER ARTICULATING TRUCK ATTACHMENTS

FOR MUNICIPAL EQUIPMENT

800-262-4360 | www.americhem.net

VERSATILE. FLEXIBLE. EFFECTIVE.



HYDRAULIC SWEEPER

Sweep like a professional. Ensure perfect sweeping results in both summer and winter, with this compact hydraulic sweeper.

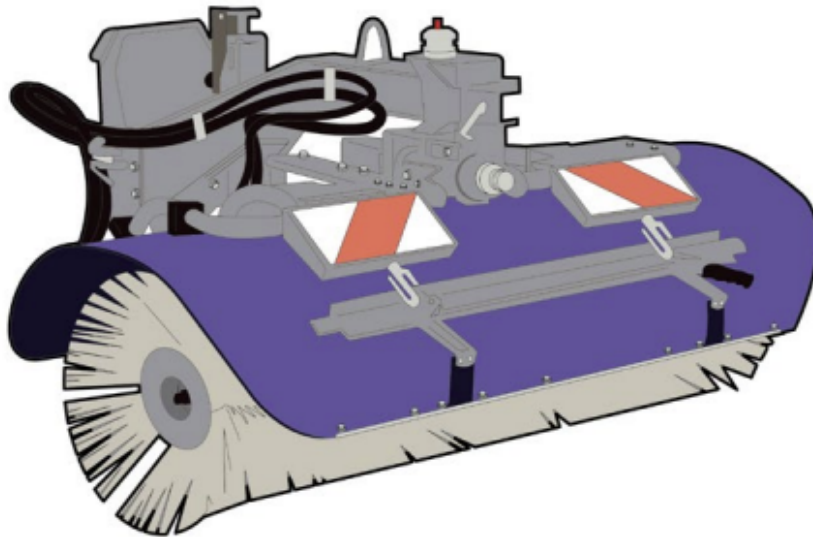

| Technical Data | SDC-055-01 | SDC-059-01 |
|-------------------------|---|----------------------------------|
| Total Width | 57" (1,447 mm) | 61" (1,550 mm) |
| Clearing Width Straight | 55" (1,400 mm) | 59" (1,500 mm) |
| Clearing Width Angled | 59" (1,500 mm) at 26° | 63" (1,600 mm) at 32° |
| Turning Angle (L/R) | 26° | 32° |
| Oscillation | No | 18° |
| Transport Height | 29" (735 mm) | 41" (1,050 mm) |
| Brush Diameter | 22" (550 mm) | 24" (600 mm) |
| Brush Material | Polypropylene | |
| Weight | 260 lb (118 kg) | 529 lb (240 kg) |
| Torque to the Shaft | 147 lb*f (200 Nm) | 479 lb*f (650 Nm) |
| Power Requirements | Flow divider 1 or high flow pump 6.6 gpm (25 l/min) | High flow pump 10 gpm (40 l/min) |



Standard Features:

- Adjustable broom cover
- Only for SCD-059-01: castor wheel

Available Options:

- Only for SCD-059-01: wet kit (spray nozzles electrical pump) (regular water tank is required)

Compatible Machines:

- SDC-055-01: C70 – C270 – S75
- SDC-059-01: C70 – C270 – S75 – S100

PTO DRIVEN SWEEPER

Sweep in any season. This versatile sweeper is ideal in any situation. Effortlessly sweep away salt, dirt, snow and other debris. Sweeping width options from 48" to 60".

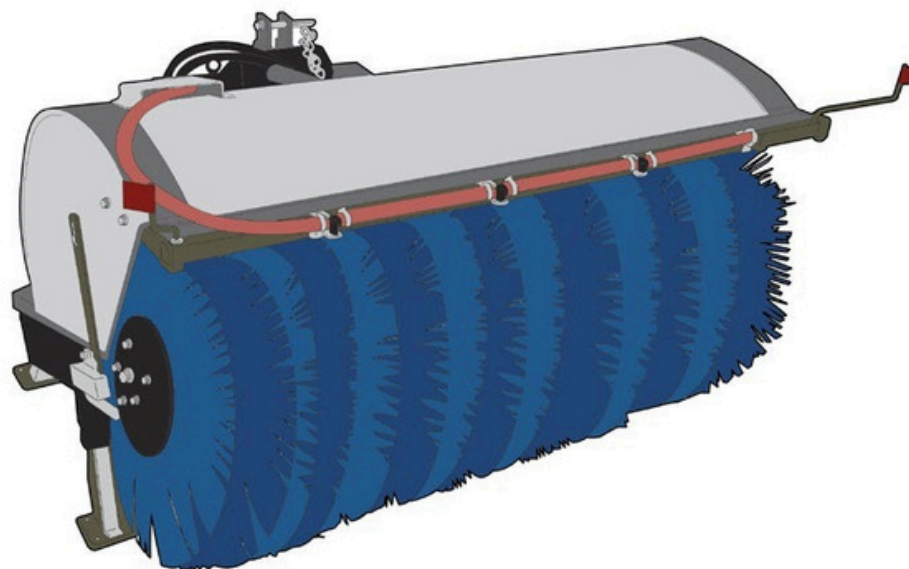

| Technical Data | SPT-048-02 | SPT-060-02 | SPT-072-02 |
|---------------------------|--------------------------------|---------------------------------------|--------------------------|
| Total Width | 53" (1,346 mm) | 65" (1,651 mm) | 77" (1,955 mm) |
| Clearing Width Straight | 48" (1,219 mm) | 60" (1,524 mm) | 72" (1,828 mm) |
| Clearing Width Angled 30° | 42" (1,066 mm) | 52" (1,320 mm) | 62" (1,574 mm) |
| Height | 38" (965 mm) | | |
| Brush Diameter | 32" (812 mm) | | |
| Swing Angle | 30° | | |
| Drive Assembly | Side Drive via Gearbox & Chain | | |
| Type | Mechanical | | |
| Weight | 685 lb (310 kg) | 780 lb (353 kg) | 860 lb (390 kg) |
| Power Requirements | 40 HP (30 kW) | | |
| Tractor Fit (Holder) | C70 – C270 | C70 – C270 – C992 – S75 – S100 – S130 | C992 – S75 – S100 – S130 |



Standard Features:

- PU cowling
- Parking legs
- Poly steel combination brushes
- Water spray bar
- Water pump
- Adapter plate for wheel kit

Available Options:

- Stainless steel or steel cowling
- Wheel kit
- Hydraulic driven models available

Tractor Requirements:

- CAT I | CAT II (3-point hitch)

Compatible Machines:

- SPT-048-02: C70 – C270
- SPT-060-02: C70 – C270 – S75 – S100 – S130
- SPT-072-02: S75 – S100 – S130

WATER TANKS

Whether you're sweeping and cleaning, watering greenery, or de-icing, these water tanks will allow you to accomplish any of those tasks. Transport water, brine, liquid de-icer, and more with ease. Holder C 70 water tanks range from 100 gallons (440 litres) to 175 gallons (771 litres).

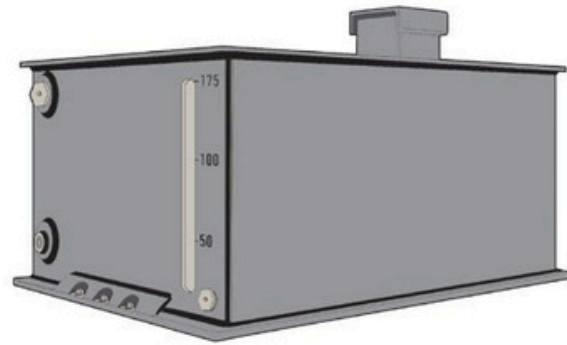
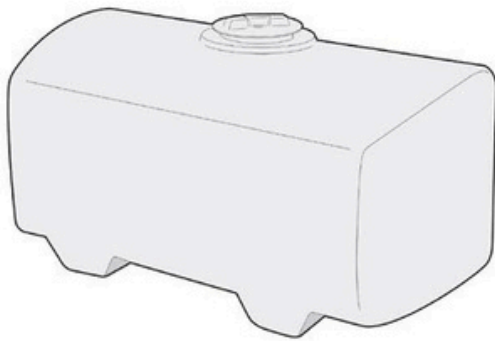

| Technical Data | SPT-048-02 | SPT-060-02 | SPT-072-02 |
|---------------------------|--------------------------------|---------------------------------------|--------------------------|
| Total Width | 53" (1,346 mm) | 65" (1,651 mm) | 77" (1,955 mm) |
| Clearing Width Straight | 48" (1,219 mm) | 60" (1,524 mm) | 72" (1,828 mm) |
| Clearing Width Angled 30° | 42" (1,066 mm) | 52" (1,320 mm) | 62" (1,574 mm) |
| Height | 38" (965 mm) | | |
| Brush Diameter | 32" (812 mm) | | |
| Swing Angle | 30° | | |
| Drive Assembly | Side Drive via Gearbox & Chain | | |
| Type | Mechanical | | |
| Weight | 685 lb (310 kg) | 780 lb (353 kg) | 860 lb (390 kg) |
| Power Requirements | 40 HP (30 kW) | | |
| Tractor Fit (Holder) | C70 – C270 | C70 – C270 – C992 – S75 – S100 – S130 | C992 – S75 – S100 – S130 |



Standard features (WTA-100-01):

- Hose connections

Mounting options (WTA-100-01):

- In the dump body (*frame required*)
- On the platform (*frame required*)

Frame options (WTA-100-01):

- WTF-100-01 (*dump body mount*)
- WTF-100-02 (*platform mount*)

Tractor requirements (WTA-100-01):

- Over-engine platform or in the dump body

Standard features (WTA-175-01):

- Hose connections
- Platform mount

Mounting options (WTA-175-01):

- On the platform only

Tractor requirements (WTA-175-01):

- Over-engine platform

Compatible Machines:

- WTA-100-01: C70 – C270
- WTA-150-01: S75 – S100 – S130
- WTA-175-01: C70 – C270
- WTA-250-01: S75 – S100 – S130

BRINE SPRAYER

If you have brine to spread or are tasked with cleaning sports grounds and small parks, the brine sprayer attachment is for you.

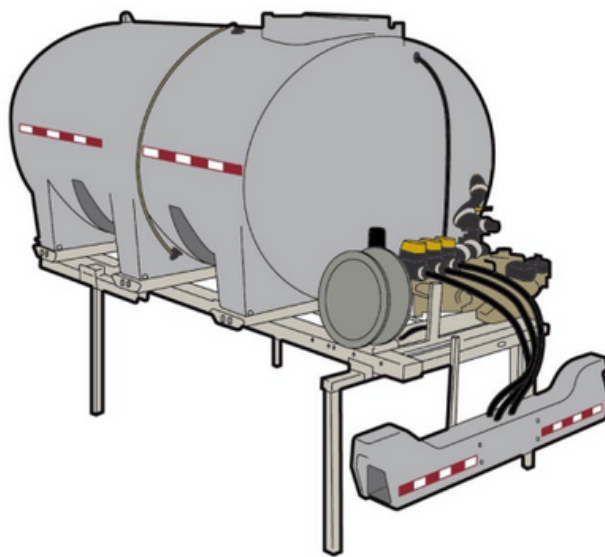

| Specification | BSP-250-75 |
|----------------------|--------------------------------|
| Total Volume | 250 gal (946 L) |
| Length | 81" (2057 mm) |
| Width | 48" (1219 mm) |
| Height | 39" (991 mm) |
| Weight (Empty) | 475 lb (215 kg) |
| Frame Type | Stainless Steel |
| Hose Length | 100' (30 m) |
| Mounting | 4 Tie-Down Slots |
| Tank Type | Single-Piece Roto Mold HDPE |
| Spray Gun Type | Adjustable Jet/Fan |
| Power Requirements | 70 HP – 130 HP (52 kW – 97 kW) |
| Tractor Fit (Holder) | S75 – S100 – S130 |



Standard features:

- Double spray bar system
- Baffle ball surge control
- Fast fill system
- Tri-zone spray selection
- Auto drain sump base
- Built-in fork slots
- Rust armor stainless frame

Available options:

- Storage stands & lights
- Securing bar
- Pump options: high flow 12-volt, gas or hydraulic

Tractor requirements:

- Over-engine platform

Compatible Machines:

- BSP-250-75: S75 – S100 – S130

ROTARY MOWER DECK

Rotary mower decks, also known as grooming mowers, are designed for commercial mowing applications and are the ideal machines for landscapers, municipal parks, golf courses and other sports complexes.

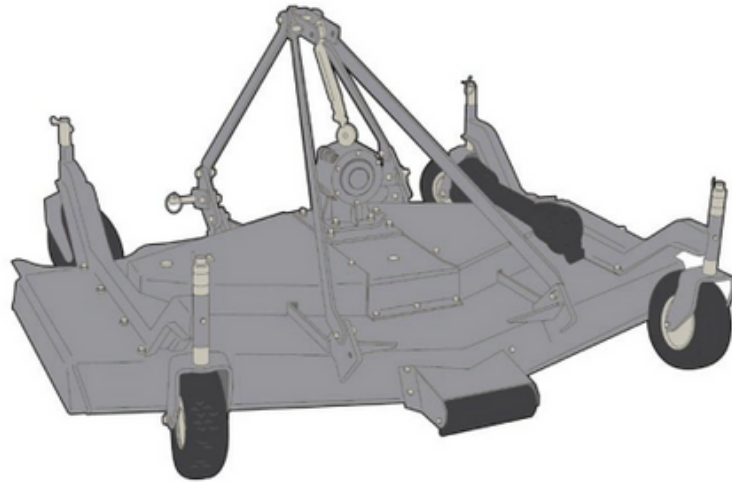

| Technical Data | MRT-060-01 | MRT-072-01 | MRT-084-01 | MRT-090-01 | MRT-110-01 |
|------------------------|--|-------------------------------|-------------------------------|--|-------------------------------|
| Working Width | 60" (1524 mm) | 72" (1829 mm) | 84" (2134 mm) | 90" (2286 mm) | 110" (2794 mm) |
| Overall Width | 62" (1575 mm) | 74" (1880 mm) | 86" (2184 mm) | 92" (2336 mm) | 112" (2844 mm) |
| Weight | 534 lb (242 kg) | 584 lb (265 kg) | 674 lb (306 kg) | 1137 lb (515 kg) | 1290 lb (585 kg) |
| Rotor RPM | 3210 | 2605 | 2195 | 1750 | 1562 |
| Blade Tip Speed | 16,929 ft/min (5160 m/min) | 16,732 ft/min (5100 m/min) | 16,338 ft/min (4980 m/min) | 14,106 ft/min (4299 m/min) | 14,998 ft/min (4571 m/min) |
| Number of Blades | 3 | | | 6 | |
| Cutting Height | 1" – 5" (25 mm – 127 mm) | | | 1.3" – 5.3" (33 mm – 134 mm) | |
| Number of Belts & Type | 2 SPBX | | | 2 CX | |
| Driveline | 1 3/8" ASAE CAT 3 | | | 1 3/8" ASAE CAT 4 | |
| Tires | Pneumatic (4) 11" x 4" (279 mm x 101 mm) | | | Pneumatic (4) 13" x 6.5" (330 mm x 165 mm) | |
| Gearbox | Spiral Gears w/ Cooling Fins | | | | |
| Power Requirements | 20 HP – 50 HP (15 kW – 37 kW) | 25 HP – 50 HP (18 kW – 37 kW) | 30 HP – 50 HP (22 kW – 37 kW) | 30 HP – 70 HP (22 kW – 52 kW) | 40 HP – 70 HP (29 kW – 52 kW) |
| Tractor Fit (Holder) | C70 – C270 | | | C992 – S75 – S100 – S130 | |

**Standard features:**

- Gearbox w/ spiral gears
- Manual belt tensioning
- Stamped steel reinforced wheel arms
- Double belt transmission
- Cast iron pulleys
- Axial grease fittings
- 8 gauge reinforced mower deck
- Safety chain shield

Available options:

- Quick hitch adapter
- Mulching kit
- Front anti-scalp roller

Available Blade Options:

- Standard blades
- Low lift blades
- High lift blades
- Mulching blades

Tractor Requirements:

- 540 RPM
- CAT I (3-point hitch)
- Front and rear mounting

Compatible Machines:

- MRT-060-01: C70 – C270
- MRT-072-01: C70 – C270
- MRT-084-01: C70 – C270
- MRT-090-01: S75 – S100 – S130
- MRT-110-01: S75 – S100 – S130

TRI-DECK MOWER

Tri-deck mowers, also known as finishing mowers, are ideal for residential and professional use alike.

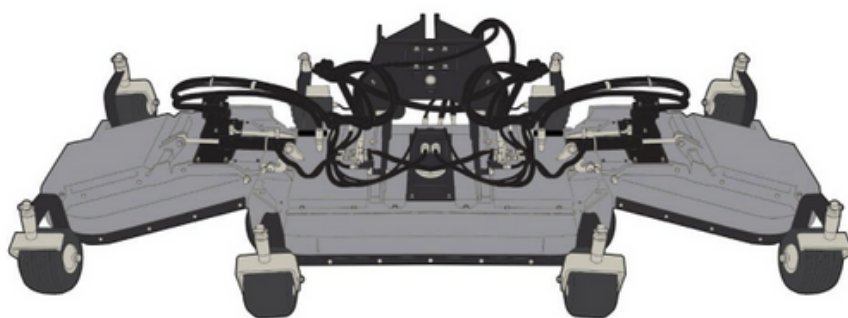

| Technical Data | MTD-098-02 | MTD-114-02 | MTD-136-02 | MTD-159-02 |
|----------------------|--|--|---|--|
| Largest Width | 100" (2535 mm) | 117" (2975 mm) | 139" (3525 mm) | 162" (4120 mm) |
| Transport Width | 69" (1750 mm) | 79" (2000 mm) | 69" (1750 mm) | 79" (2000 mm) |
| Largest Length | 61" (1550 mm) | 65" (1655 mm) | 64" (1625 mm) | 68" (1735 mm) |
| Largest Height | 20" (500 mm) | | 24" (600 mm) | |
| Transport Height | 32" (820 mm) | 36" (920 mm) | 47" (1200 mm) | 57" (1450 mm) |
| Cutting Width | 98" (2480 mm) | 114" (2900 mm) | 136" (3460 mm) | 158" (4025 mm) |
| Cutting Height | 1" – 3" (30 mm – 80 mm) | | 1" – 3" (30 mm – 80 mm) | |
| Necessary Flow | 16 gal @ 3625 psi (60 L/min @ 250 bar) | 18 gal @ 3625 psi (70 L/min @ 250 bar) | 16 gal @ 3625 psi (80 L/min @ 250 bar) | 18 gal @ 3625 psi (85 L/min @ 300 bar) |
| Number of Rotors | 5 | | 7 | |
| Number of Knives | 5 x 21" (533 mm) | 5 x 24" (620 mm) | 7 | |
| Tires | Air Rubber Tires (6) 10" x 3" | | Air Rubber Tires (8) 11" x 7" (279 mm x 177 mm) | |
| Weight | 804 lb (365 kg) | 970 lb (440 kg) | 1146 lb (520 kg) | 1323 lb (600 kg) |
| Power Requirements | 34 HP (25 kW) | 41 HP (30 kW) | 51 HP (37.5 kW) | 56 HP (41.5 kW) |
| Tractor Fit (Holder) | C70 – C270 | C70 – C270 – S75 – S100 – S130 | S75 – S100 – S130 | S75 – S100 – S130 |



Standard Features:

- Mechanical tilt up
- Cut 10° below level and 15° above (when floated)
- Hydraulic transmission via direct drive
- Automatic shut off on the side wings when raised more than 15" (400 mm)

Available Options:

- Hydraulic tilt up
- Mechanical main deck

Tractor Requirements:

- CAT I | CAT II (3-point hitch)
- High-flow pump
- Counterweight
- Turf tires
- 2 sets of hydraulic quick couplings (double acting) w/ float mode

Compatible Machines:

- MTD-098-02: C70 – C270
- MTD-114-02: C70 – C270 – S75 – S100 – S130
- MTD-136-02: S75 – S100 – S130
- MTD-159-02: S75 – S100 – S130

FLAIL MOWER

Flail mowers are perfect for roadside mowing and clearing recreational areas such as schoolyards and parks.

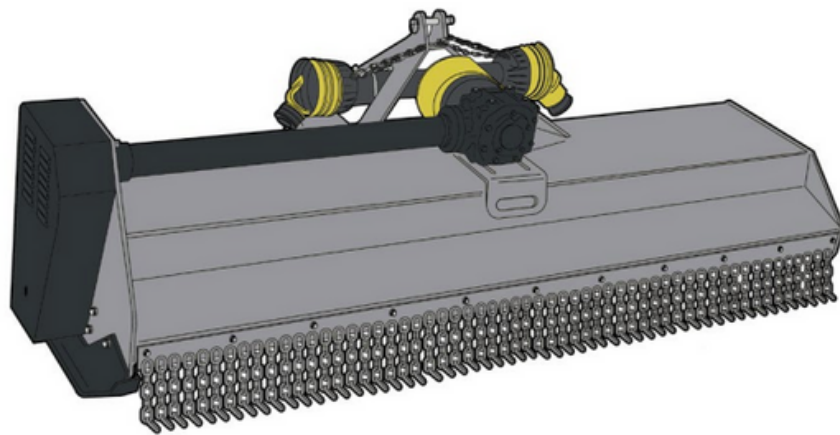

| Technical Data | MFL-060-01 | MFL-072-01 | MFL-088-01 | MFL-060-03 | MFL-072-03 |
|------------------------|--------------------------------------|--------------------------------|-------------------------------|--------------------------------------|-------------------------------|
| Working Width | 60" (1524 mm) | 72" (1829 mm) | 88" (2235 mm) | 60" (1524 mm) | 72" (1829 mm) |
| Overall Width | 71" (1803 mm) | 85" (2159 mm) | 99" (2515 mm) | 69" (1752 mm) | 81" (2057 mm) |
| Weight | 869 lb (394 kg) | 955 lb (433 kg) | 1078 lb (489 kg) | 1257 lb (570 kg) | 1345 lb (610 kg) |
| Rotor RPM | 2080 | | | 1961 | |
| Blade Tip Speed | 8464 ft/min (2579 m/min) | | | 8268 ft/min (2520 m/min) | |
| Number of Blades | 64 | 80 | 96 | - | - |
| Number of Hammers | - | - | - | 16 | 20 |
| Cutting Height | 3/4" - 6" (19 mm - 152 mm) | | | 3/4" - 5" (19 mm - 127 mm) | |
| Number of Belts & Type | 2 CX | | | 4 XPBX | |
| Driveline | 1 3/8" ASAE CAT 4 Overrunning Clutch | | | 1 3/8" ASAE CAT 6 Overrunning Clutch | |
| Hydraulic Side-Shift | - | | | 12" (304 mm) | 16" (406 mm) |
| Power Requirements | 30 HP - 70 HP (22 kW - 52 kW) | 35 HP - 70 HP (26 kW - 52 kW) | 40 HP - 70 HP (30 kW - 52 kW) | 40 HP - 80 HP (30 kW - 60 kW) | 50 HP - 90 HP (37 kW - 67 kW) |
| Tractor Fit (Holder) | C70 - C270 | C70 - C270 - S75 - S100 - S130 | S100 - S130 | S75 - S100 - S130 | S75 - S100 - S130 |



Standard Features:

- Cast iron rotor supports
- Belt shield fender
- Replaceable side skids
- Clockwise rotor rotation

Available Options:

- Gauge wheels
- Front mount
- Reverse rotation
- Metal dust skirt

Available Blade Options (all factory installed):

- Dethatching
- Reverse "Y"
- Triangular paddle
- Hammer

Tractor Requirements:

- 540 RPM
- CAT I (3-point hitch)
- Front and rear mounting

Compatible Machines:

- MFL-060-01: C70 – C270
- MFL-072-01: C70 – C270 – S75 – S100 – S130
- MFL-088-01: S100 – S130
- MFL-060-03: S75 – S100 – S130
- MFL-072-03: S75 – S100 – S130

TURBINE BLOWER

Powerful and versatile. This turbine style PTO driven blower is ideal for clearing leaves, foliage and other debris.

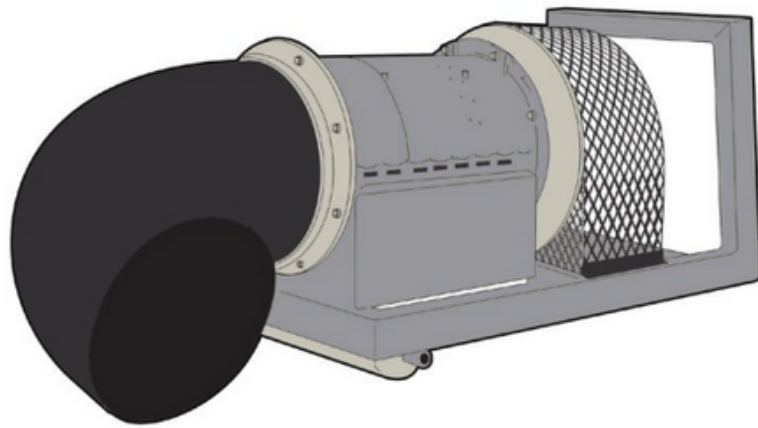

| Technical Data | BDS-033-01 |
|--------------------|--|
| Total Length | 63" (1,600 mm) |
| Total Width | 22" (559 mm) |
| Total Height | 24" (610 mm) |
| Weight | 245 lb (111 kg) |
| Input Power | Direct drive gearbox |
| Input RPM | Use only @ 540 RPM PTO shaft speed max |
| Output RPM | Up to 3,780 RPM |
| Nozzle | Aerospace polymer nozzle |
| Outlet Size | Approx. 12" (305 mm) |
| Power Requirements | 20 HP (15 kW) |



Standard Features:

- Heavy duty steel construction
- Direct drive gearbox
- 360° nozzle control
- Anti-scalping roller for soft surfaces
- Plastic shielded telescopic PTO shaft
- PTO shaft safety / retaining chain
- Hitch pins & top link pin

Available Options:

- Waterproof cover
- Optional rectangular aluminum nozzle 10" (254 mm)
- Optional rectangular aluminum nozzle 19" (483 mm)

Tractor Requirements:

- 540 RPM

Compatible Machines:

- BDS-033-01: C70

HEAVY DUTY MULCHER

This light-weight, fixed-tooth masticating head brush mulcher will efficiently cut heavy vegetation and light brush using high speed teeth.

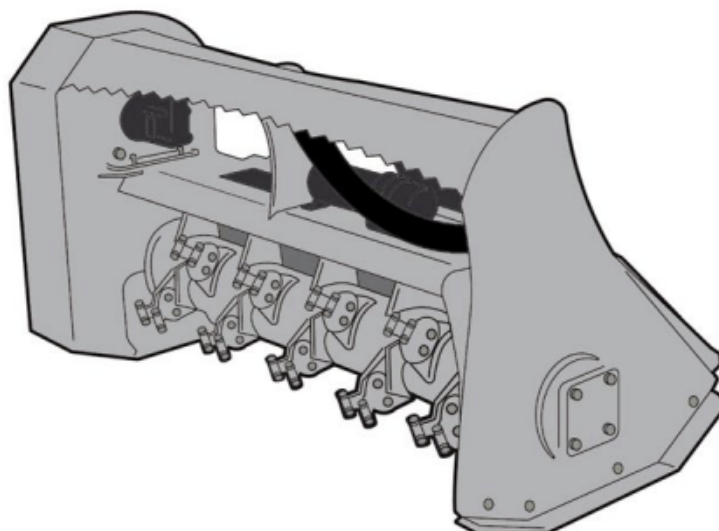

| Technical Data | HDM-060-01 |
|----------------------|-------------------------------|
| Path Width | 60" (1524 mm) |
| Rotor Width | 48" (1219 mm) |
| Cutting Style | High Speed Teeth |
| Number of Teeth | 60 |
| Rotor Shaft Size | 2" (51 mm) |
| Rotor Diameter | 15" (381 mm) |
| Weight | 1050 lb (476 kg) |
| RPM | 1800 |
| Drive Speed | 540 RPM |
| Power Requirements | 25 HP – 50 HP (18 kW – 37 kW) |
| Tractor Fit (Holder) | S100 – S130 |



Standard Features:

- Integrated brush bar
- Integrated skid shoes
- High speed teeth
- Spiral tooth pattern
- Heavy duty gearbox
- Reinforced belt
- Powder coat
- Wire protection kit
- Slip clutch protection

Tractor Requirements:

- CAT II (3-point hitch)

Compatible Machines:

- HDM-060-01: S100 – S130

COLD PLANER

Cut asphalt and concrete with carbide teeth. This highly versatile cold planer is adaptable to a wide variety of job environments including road repair, landscaping, municipal, parking lots, and more.

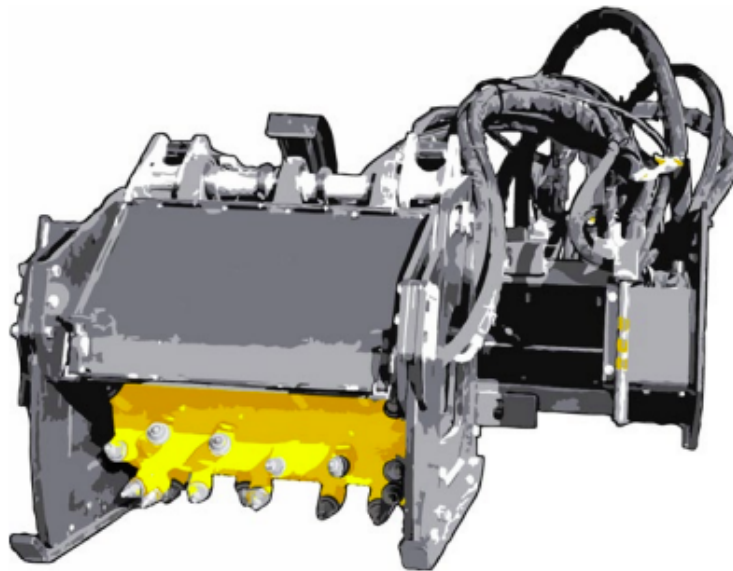

| Technical Data | CPH-024-01 |
|------------------------|--|
| Depth of Cut | 0 – 6" (0 – 152 mm) |
| Width of Cut | 24" (610 mm) |
| Number of Teeth | 60 |
| Standard Side-Shift | 24" (610 mm) hydraulic |
| Tilt | 16° |
| Weight | 1,825 lb (828 kg) |
| Hydraulic Requirements | 25 gpm @ 3,000 psi – 56 gpm @ 6,525 psi (95 l/min @ 207 bar – 212 l/min @ 450 bar) |



Standard Features:

- Solid drum design
- Right & left side skid shoes can be controlled independently
- Side-shift feature moves planer from left to right

Available Options:

- Bolt-on rollers
- Pistol grip control harness
- Loader specific wire harness
- Case drain coupler required
- Factory installed couplers
- Factory installed high flow couplers

Compatible Machines:

- CPH-024-01: C70

HYDRAULIC WATERING ARM

Reach new heights with this hydraulic watering arm. Easily water flower beds, hanging baskets, trees and more. This watering arm's ability to extend and articulate allow it to avoid and move around most obstacles such as park benches, guard rails, garbage cans, etc.



Standard Features:

- Flat sealing couplings
- Electrical angling of the spraying head
- Standard Holder joystick controls

Available Options:

- FMC multimatic control box w/ joystick (WAR-161-02)
- Tractor requirements:
- CAT I | CAT II (3-point hitch)
 - 2 sets of hydraulic quick couplers (double acting)

Other Requirements:

- Water tank system WTS-171-01 OR WTS-171-02

Compatible Machines:

- WAR-161-01: C270 – C70 – S75 – S100 – S130

| Technical Data | WAR-161-01 |
|-----------------------|--------------------------------|
| Working Height | 161" (4100 mm) |
| Swivel Range (L/R) | 250° (125° L/R) |
| Main Arm Tilt | 55° Tilt |
| Secondary Arm Swivel | 150° Swivel |
| Spraying Head Angling | 170° Electrically Adjustable |
| Material (Both Arms) | Stainless Steel |
| Power Requirements | 13 gpm (51 L/min) |
| Tractor Fit (Holder) | C270 – C70 – S75 – S100 – S130 |

HYDRAULIC POWER ARM

Extend your capabilities with a power arm, also known as a boom arm. Equipping a flail head mower to this power arm enables you to reach less than ideal areas such as sloped hillsides, underneath guard rails, and more.



| Specification | PAR-157-01 | PAR-157-02 | PAR-157-03 |
|---------------------------|--|--|--|
| REACH FROM TRACTOR CENTER | 157" (3988 mm) | 157" (3988 mm) | 157" (3988 mm) |
| OPERATION | HYDRAULIC – HI FLOW | HYDRAULIC – HI FLOW | 1000 RPM – PTO DRIVEN |
| WEIGHT | approx. 639 lb (290 kg) | approx. 639 lb (290 kg) | approx. 639 lb (290 kg) |
| POWER REQUIREMENTS | 3.96 gpm @ 2900 psi (15 L/min @ 200 bar) | 3.96 gpm @ 2900 psi (15 L/min @ 200 bar) | 3.96 gpm @ 2900 psi (15 L/min @ 200 bar) |
| TRACTOR FIT (HOLDER) | S75 – S100 – S130 | C70 – C270 | S75 – S100 – S130 |

| Specification | PAR-320-01 |
|---------------------------|---------------------------------------|
| REACH FROM TRACTOR CENTER | 128" (3251 mm) |
| OPERATION | HYDRAULIC |
| WEIGHT | 1058 lb (480 kg) |
| POWER REQUIREMENTS | 30 HP (22 kW) |
| OIL TANK CAPACITY | 16 gal (62 L) |
| TRACTOR FIT (HOLDER) | C270 – C70 – C992 – S75 – S100 – S130 |



Standard Features (HMF-039-02):

- Quick change system
- Direct drive via axial piston engine
- Support roller for cutting height regulation
- Double stone guard at the front (plastic baffle plates & chain guard)
- Simple impact protection at the back (rubber apron)

Standard Features (PAR-157-02):

- Hydraulic weight transfer
- Flat sealing couplings
- Hydraulic anti-crash protection
- Holder mounting group
- Quick change system for working tools

Available Options (PAR-157-02):

- FMC multimatec control box w/ digital mouse

Tractor Requirements (PAR-157-02):

- Counterweight

Compatible Machines:

- PAR-157-01: S75 – S100 – S130
- PAR-157-02: C70 – C270
- PAR-157-03: S75 – S100 – S130
- PAR-320-01: C270 – C70 – S75 – S100 – S130

FLAIL HEAD POWER ARM ATTACHMENT

The flail head attachment will easily maneuver around obstacles to control overgrown grass and vegetation.

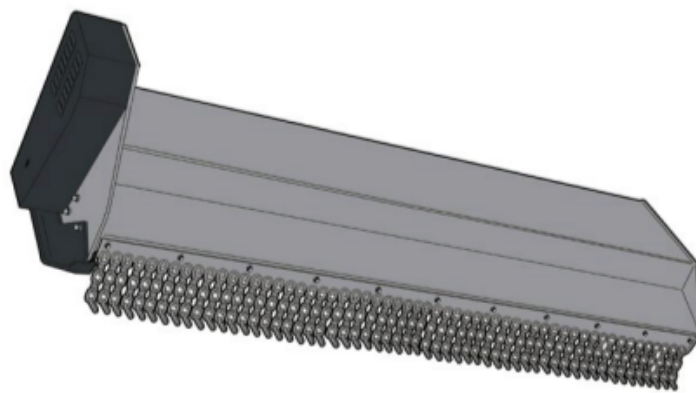

Standard features:

- Quick change system
- Direct drive via axial piston engine
- Support roller for cutting height regulation
- Double stone guard at the front (plastic baffle plates & chain guard)
- Simple impact protection at the back (rubber apron)

Tractor Requirements:

- Multi-purpose hydraulic power arm (boom arm) PAR-157-XX

Compatible Machines:

- PAR-157-01: S75 – S100 – S130
- PAR-157-02: C70 – C270
- PAR-157-03: S75 – S100 – S130

| | |
|-------------------|---------------------------|
| Model | HMF-039-02 |
| Grass Trim Height | Cut up to Ø 0.78" (20 mm) |
| Working Width | 31.5" (800 mm) |
| Number of Blades | 32 Y-blades |
| Weight | approx. 363 lb (165 kg) |

BRANCH CUTTER POWER ARM ATTACHMENT

The branch cutter attachment was created to allow operators to swiftly and easily remove weeds, thick grass and greenery from parks, waterfronts, suburban areas and more.

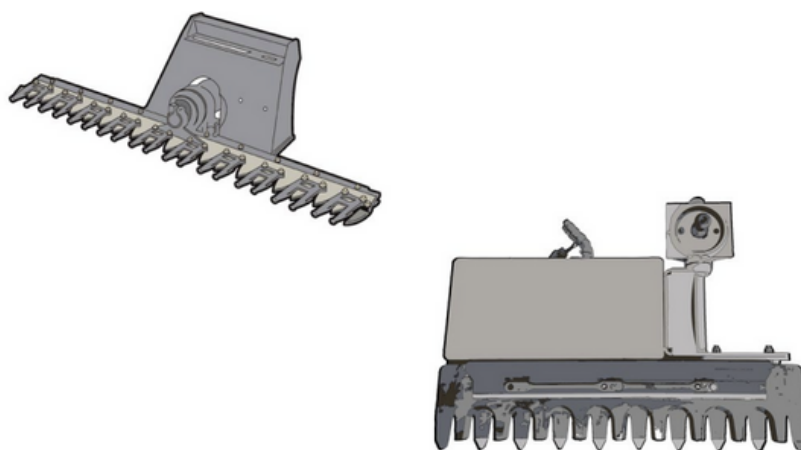

Standard features:

- Quick change system

Available Options:

- Additional sizes available

Tractor Requirements:

- Multi-purpose hydraulic power arm (boom arm) PAR-320 & PAR-157-XX

Compatible Machines:

- PAR-157-01: S75 – S100 – S130
- PAR-157-02: C70 – C270
- PAR-157-03: S75 – S100 – S130
- PAR-320-01: C270 – C70 – S75 – S100 – S130

| Model | BCH-059-01 |
|--------------------|---------------------|
| Cutting Width | 4'9" (1.5 m) |
| Number of Blades | 19 |
| Strokes per Minute | 60 |
| Cutting Capacity | 1.57" (40 mm) |
| Minimum Flow | 13.2 gpm (50 L/min) |
| Pressure | 2611 psi (180 bar) |

| Model | BCH-053-01 |
|----------------------|----------------------|
| Cutting Width | 4.42' (1347 mm) |
| Cuttable Branch Size | max. 3.93' (1197 mm) |
| Strokes per Minute | 100 |
| Weight | 410 lb (186 kg) |

HEDGE TRIMMER POWER ARM ATTACHMENT

This attachment effortlessly cuts through brush in order to maintain greenery surrounding parks, cities, suburban areas and recreational areas.

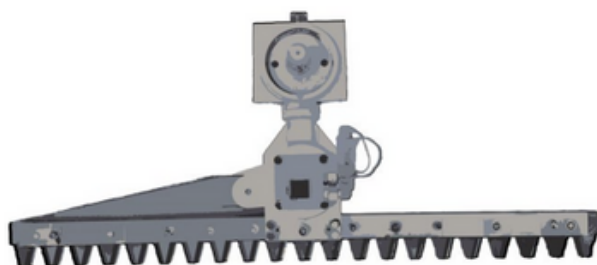
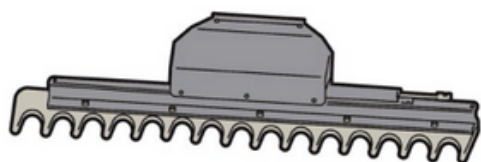

Standard features:

- Quick change system

Available Options:

- Additional sizes available

Tractor Requirements:

- Multi-purpose hydraulic power arm (boom arm) PAR-320 & PAR-157-XX

Compatible Machines:

- PAR-157-01: S75 – S100 – S130
- PAR-157-02: C70 – C270
- PAR-157-03: S75 – S100 – S130
- PAR-320-01: C270 – C70 – S75 – S100 – S130

| Model | BCH-059-01 |
|--------------------|---------------------|
| Cutting Width | 4'9" (1.5 m) |
| Number of Blades | 19 |
| Strokes per Minute | 60 |
| Cutting Capacity | 1.57" (40 mm) |
| Minimum Flow | 13.2 gpm (50 L/min) |
| Pressure | 2611 psi (180 bar) |

| Model | BCH-053-01 |
|---------------------|----------------------|
| Cutting Width | 4.42' (1347 mm) |
| Cutable Branch Size | max. 3.93' (1197 mm) |
| Strokes per Minute | 100 |
| Weight | 410 lb (186 kg) |

QUADSAW POWER ARM ATTACHMENT

The quadsaw attachment smoothly cuts tree and hedge branches, making city beautification and pathway maintenance even easier.

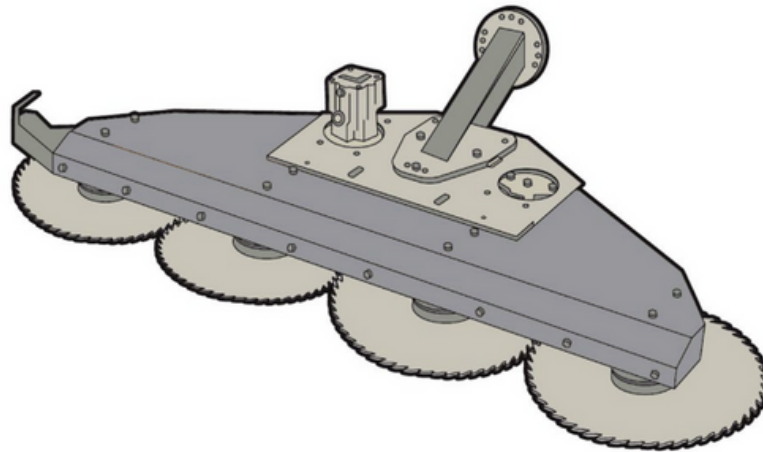

Standard features:

- Low noise levels
- High speed belt drive
- Tungsten carbide tipped blades

Available Options:

- Manual quick release kit
- Hydraulic quick release kit
- Trisaw also available - (3 circular saw blades)

Tractor Requirements:

- Multi-purpose hydraulic power arm (boom arm) PAR-320-01

Compatible Machines:

- PAR-320-01: C270 - C70 - S75 - S100 - S130

| | |
|------------------|-----------------------------------|
| Model | MSH-058-01 |
| Cutting Width | 6'5" (2 m) |
| Number of Blades | 4 Circular Saw Blades |
| Cutting Capacity | 5.9" (150 mm) |
| Minimum Flow | 22.19 - 22.98 gpm (84 - 87 L/min) |
| Pressure | 3191 psi (220 bar) |

ROTARY FINISHING HEAD POWER ARM ATTACHMENT

Mow overgrown grass, brush and greenery with ease using the rotary finishing head attachment for your hydraulic power head.

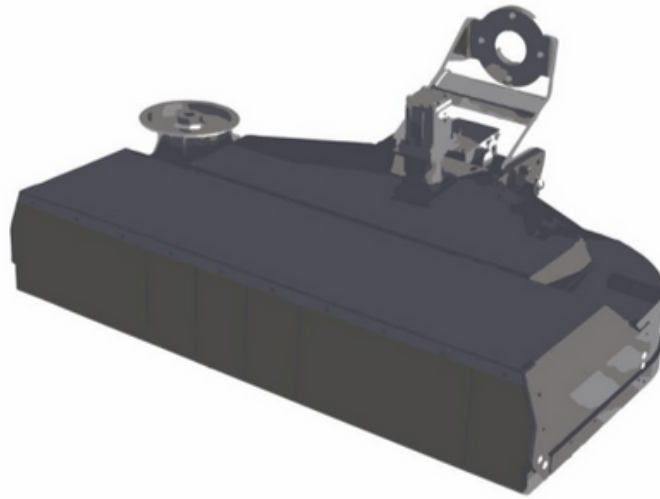

Standard features:

- Branch guide
- Front rubber flap
- High speed belt drive
- (6) blade X (3) rotor fine cut cutting system

Available Options:

- Manual quick release kit
- Hydraulic quick release kit

Tractor Requirements:

- Multi-purpose hydraulic power arm (boom arm) PAR-320-01

Compatible Machines:

- PAR-320-01: C270 – C70 – S75 – S100 – S130

| Model | MRH-050-01 |
|------------------|----------------------|
| Cutting Width | 4'2" (1.3 m) |
| Number of Blades | 18 |
| Cutting Capacity | 1.81" (30 mm) |
| Minimum Flow | 11.88 gpm (45 L/min) |
| Pressure | 2610 psi (180 bar) |

DITCH DIGGER POWER ARM ATTACHMENT

Sever tree roots, create drainage ditches and more for your project using the ditch digger attachment.



Standard features:

- Quick change system
- Adjustable discharge center

Tractor Requirements:

- Multi-purpose hydraulic power arm (boom arm) PAR-57-XX

Compatible Machines:

- PAR-157-01: S75 – S100 – S130
- PAR-157-02: C70 – C270
- PAR-157-03: S75 – S100 – S130

| | |
|------------------|----------------------|
| Model | MRH-050-01 |
| Cutting Width | 4'2" (1.3 m) |
| Number of Blades | 18 |
| Cutting Capacity | 1.81" (30 mm) |
| Minimum Flow | 11.88 gpm (45 L/min) |
| Pressure | 2610 psi (180 bar) |

STUMP GRINDER POWER ARM ATTACHMENT

Increase operator productivity by using a stump grinder attachment for your hydraulic power head to break down tree stumps.

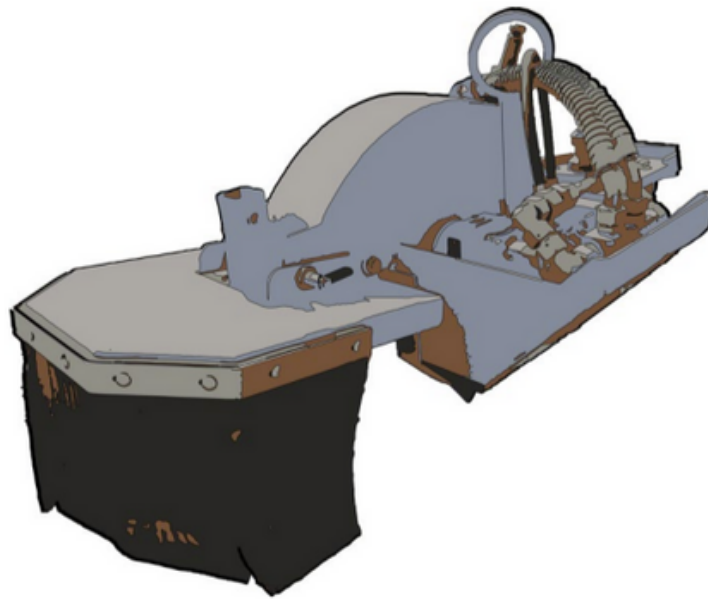

Standard features:

- Quick change system
- Drive via axial piston engine
- Robust transmission gear (without chain)

Tractor Requirements:

- Multi-purpose hydraulic power arm (boom arm) PAR-57-XX

Compatible Machines:

- PAR-157-01: S75 – S100 – S130
- PAR-157-02: C70 – C270
- PAR-157-03: S75 – S100 – S130

| | |
|-----------------------|--|
| Model | SGH-021-01 |
| Milling Disc Diameter | 21.65" (549 mm) |
| Number of Teeth | 20 Carbide Tips |
| Working Depth | 15.75" (400 mm) |
| Weight | 132 lb (60 kg) |
| Power | 33.5 HP (25 kW) |
| Oil Quantity Required | 14.5 gpm @ 2900 psi (55 L/min @ 200 bar) |

EARTH AUGER POWER ARM ATTACHMENT

You can expect efficiency and precision when digging, planting and installing during projects using the earth auger attachment for your hydraulic power arm.



Standard features:

- Quick change system with one piece auger
- Existing drills can be used
- Drill connection Stihl drill BT 360

Tractor Requirements:

- Multi-purpose hydraulic power arm (boom arm) PAR-57-XX

Compatible Machines:

- PAR-157-01: S75 – S100 – S130
- PAR-157-02: C70 – C270
- PAR-157-03: S75 – S100 – S130

| | |
|-----------------------|---|
| Model | EAH-028-01 |
| Drilling Depth | 27" (700 mm) |
| Oil Quantity Required | 15.85 gpm @ 2900 psi (60 L/min @ 200 bar) |
| Diameter | 5.9" (150 mm) |
| Weight | 132 lb (60 kg) |
| Speed | 200 min ⁻¹ |
| Torque | 300 Nm |
| Capacity | 14 HP (11 kW) |

POST BRUSHES POWER ARM ATTACHMENT



Standard features:

- Quick change system
- Water supply activated by turning the brushes
- Stainless steel splash guard mount with internal water supply
- Water hoses and couplings
- 2 level rotatable head setting enables the washing of crash barriers, reflector posts and traffic signs

Tractor Requirements:

- Multi-purpose hydraulic power arm (boom arm) PAR-57-XX

Compatible Machines:

- PAR-157-01: S75 – S100 – S130
- PAR-157-02: C70 – C270
- PAR-157-03: S75 – S100 – S130

| | |
|----------------|---|
| Model | PWH-019-01 |
| Brush Diameter | 15.74" (400 mm) |
| Brush Length | 20.47" (520 mm) |
| Required Pump | 4.54 gpm – 6.8 gpm @ 4351 psi (10 L/min – 15 L/min @ 300 bar) |
| Weight | 165 lb (74.84 kg) |

HYDRAULIC SWEEPER WITH PICK-UP

Keep you bike paths and walkways clear with this side driven hydraulic sweeper. The additional pick up container is ideal for cleaning up leaves, twigs, stones, and other debris.

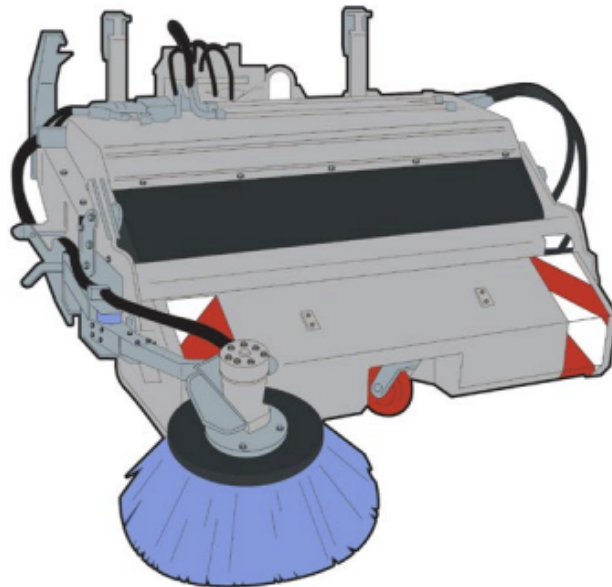

| Technical Data | SPU-051-01 |
|------------------------------------|--|
| Total width | 67" (1,700 mm) |
| Clearing width straight | 51" (1,300 mm) w/ pick-up container |
| Clearing width angled 32° | 45" (1,150 mm) w/out pick-up container |
| Working height | 38" (860 mm) |
| Transport height | 51" (1,305 mm) |
| Brush diameter | 24" (600 mm) |
| Brush material | Polypropylene |
| Weight (base sweeper) | 440 lb (200 kg) |
| Weight (max weight w/ all options) | 738 lb (335 kg) |



Standard Features:

- Broom w/ attached pick-up bucket
- Flat-face couplings

Available Options:

- Wet-kit on the basic sweeper and/or in the pick-up container: spray nozzles, electrical pump (regular water tank is required)

Available Options:

- CAT I | CAT II (3-point hitch)
- 2 sets of hydraulic quick couplers
- Double acting; high-flow pump (10 gpm (40 l /min) is required; counterweight

Compatible Machines:

- SPU-051-01: C70

VACUUM SWEEPER

Easily convert your compatible machines into a vacuum sweeper. Clean dust, pebbles, leaves and similar small debris from streets, bike paths, parking lots, and countless other areas.

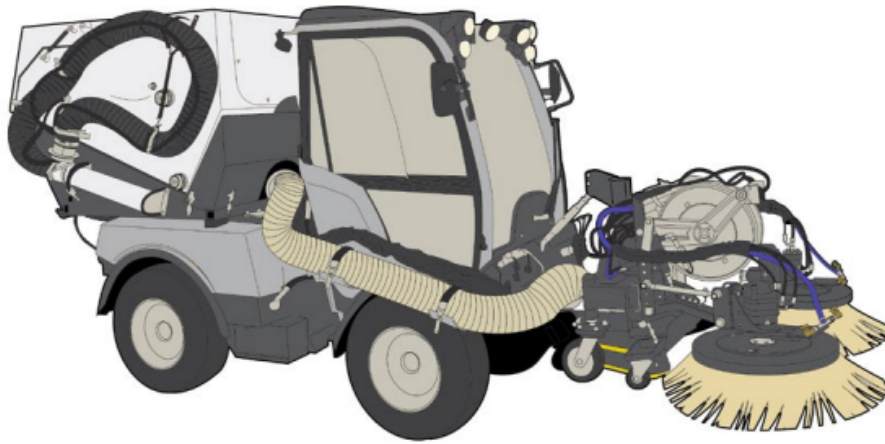

| MODEL | SVC-072-02 | SVC-200-01 |
|------------------------------|------------------------------------|-------------------------------------|
| HOPPER (GROSS) | 1.57 cu yard (1.2 m ³) | 2.1 cu yard (1.6 m ³) |
| HOPPER (NET) | 1.05 cu yard (0.8 m ³) | 1.56 cu yard (1.19 m ³) |
| FRESH WATER TANK | 58 gal (219 L) | 74 gal (280 L) |
| RECYCLED WATER | approx. 40 gal (151 L) | up to 137 gal (518 L) |
| TOTAL HEIGHT | from 84" (2133 mm) | approx. 90" (2286 mm) |
| TOTAL OUTER WIDTH | from 44" (1117 mm) | approx. 63" (1600 mm) |
| PLATE BRUSH DIAMETER | 33" (838 mm) | |
| SWEEPING WIDTH SUCTION MOUTH | 78" (1981 mm) | |
| POWER REQUIREMENTS | 45 HP – 74 HP (33 kW – 55 kW) | 70 HP – 130 HP (52 kW – 97 kW) |
| TRACTOR FIT (HOLDER) | C70 – C270 | S75 – S100 – S130 |



Standard Features:

- Robust aluminum container
- Reduced noise output
- Reduced fuel consumption
- Rear view camera
- Hand held suction hose

Available Options:

- Right or left hand brush options are available as a weed brush w/ hydraulic inclination adjustment
- Can be equipped with a hand washer that uses high-pressure water as a cleaning agent
- Can be equipped with an electric valve control on the suction mouth

Compatible Machines:

- SVC-072-02: C70 – C270
- SVC-200-01: S75 – S100 – S130

FORK LIFT & LOADER BUCKET

This fork lift and loader bucket combination is a landscaper's dream. Easily transport soil, building materials, yard waste and much more with this front loader setup.

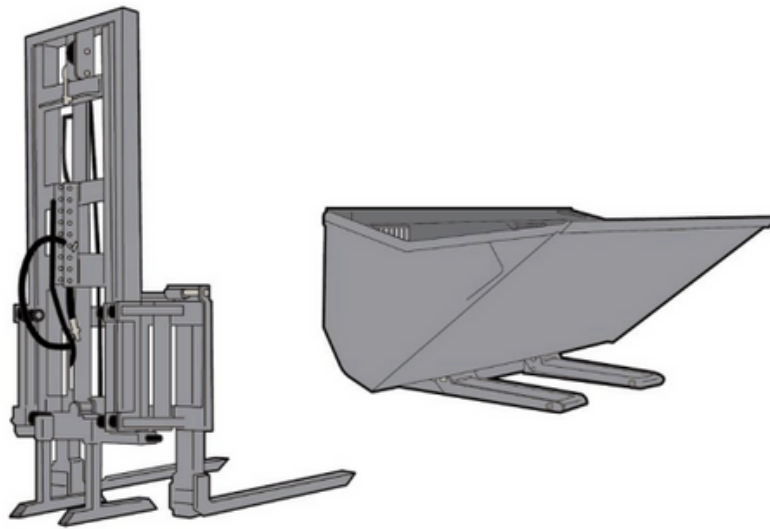

| | |
|----------------------|-------------------|
| MODEL | FKL-059-01 |
| LIFT CAPACITY | 3500 lb (1587 kg) |
| LIFT HEIGHT | 59" (1498 mm) |
| RETRACTED HEIGHT | 65" (1651 mm) |
| TRACTOR FIT (HOLDER) | S75 – S100 – S130 |

| | |
|----------------------|---------------------|
| MODEL | LOA-030-01 |
| LENGTH OF FORKS | 36" (914 mm) |
| WORKING HEIGHT | 90" (2286 mm) |
| HEIGHT | 42" (1066 mm) |
| BUCKET CAPACITY | 0.3 cu yard (229 L) |
| TRACTOR FIT (HOLDER) | S75 – S100 – S130 |

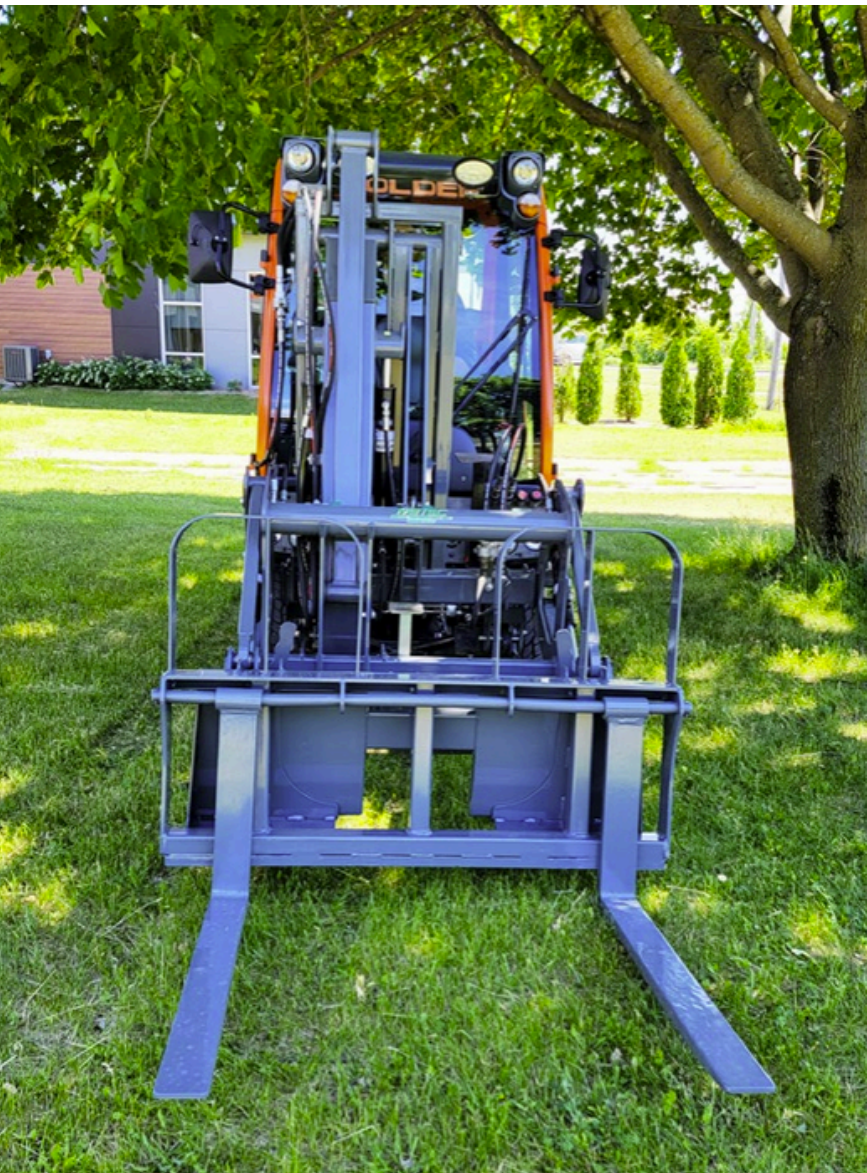

Standard Features (LOA-030-01):

- Extremely robust bulk bucket for industrial applications
- Double hinge device for a minimum loss in dump height
- All rotating points have bearings
- Round edge to prevent damage
- Complete w/ hydraulic hoses and quick connectors

Standard Features (FKL-059-01):

- Equipped w/ folding lines

Available Options (FKL-059-01):

- 60" (1,524 mm) hose kits w/ pioneer couplings

Tractor Requirements (FKL-059-01):

- CAT II
- 2 sets of hydraulic quick couplers (double acting)

Compatible Machines:

- FKL-059-01: S75 – S100 – S130
- LOA-030-01: S75 – S100 – S130

SPECIALTY ATTACHMENTS



HOT WATER WEED KILLER

This attachment kills the parts of the weeds above ground and the roots below with hot water.

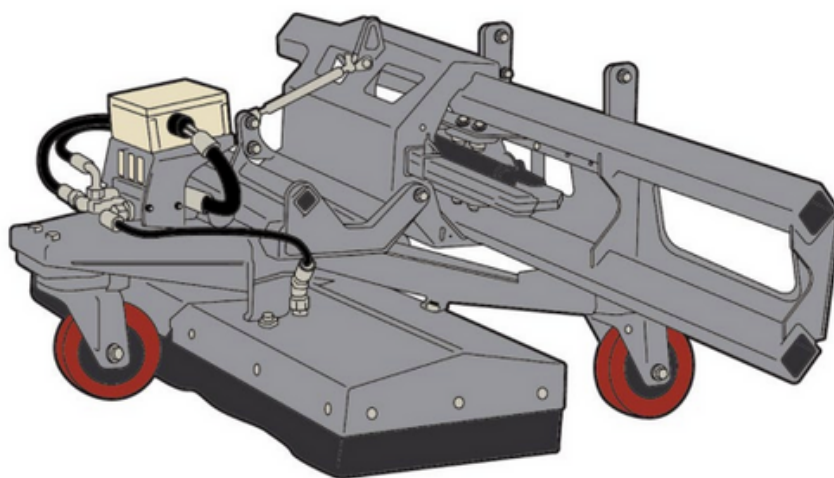

Standard features:

- Special hot water nozzles for homogeneous application
- Storage via a maintenance-free spring element
- An impeller for optimal ground-surface adaptation
- Tilt adjustment
- Storage cart w/ wheels for easy mounting

Available options:

- Stainless steel

Tractor requirements:

- Over-engine platform

Compatible machines:

- HWK-317-01: C70 – C270 – C992 – S75 – S100 – S130

| Model | HWK-317-01 |
|----------------------|---------------------------------------|
| Length | 30" (770 mm) |
| Total Width | 47" (1200 mm) |
| Working Width | 39" (1000 mm) |
| Height | 23" (540 mm) |
| Weight | 132 lb (60 kg) |
| Material | Stainless Steel V2A |
| Power Requirements | 45 HP – 130 HP (33 kW – 97 kW) |
| Tractor Fit (Holder) | C70 – C270 – C992 – S75 – S100 – S130 |

HYDRAULIC SWIVELING FRONT SPRAY BAR

This attachment helps to expedite your watering projects by giving operators the flexibility to adjust the spray bar height as well as a support leg to maintain accuracy.

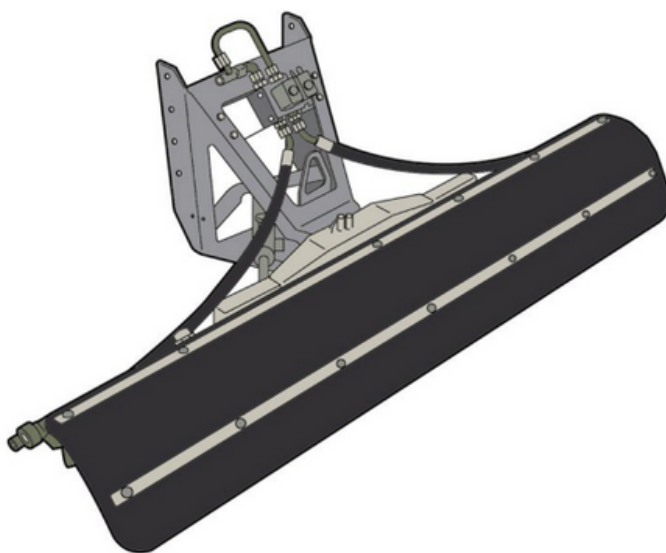

Standard features:

- Hydraulic angling (L/R)
- Manual height adjustment
- Front adapter plate holder [C250, C270, C480, C992]
- Flat-face couplings
- Support leg

Available options:

- Spray guard
- Side nozzles
- 20" (500 mm) L/R telescopic extension

Tractor requirements:

- Cat I (3 point hitch) – 1 set of hydraulic quick couplings (double acting)

Other Requirements:

- Water tank system WTS-171-02 or WTS-171-03

Compatible Machines:

- SPB-059-01: C70 – C270
- SPB-070-01: C70 – C270 – C992 – S75 – S100 – S130

| Model | SPB-059-01 | SPB-070-01 |
|-------------------------|------------------------------------|---------------------------------------|
| Total Width | 59" (1500 mm) | 70" (1778 mm) |
| Working Width 30° | 51" (1300 mm) | 62" (1574 mm) |
| Length | 19.6" (550 mm) | |
| Height | 15.7" (400 mm) | |
| Weight | 154 lb (70 kg) | 165 lb (75 kg) |
| Bar Material | Stainless Steel | |
| Power Requirements | 3.9 gpm (15 L/min) | |
| Water Pressure (Medium) | 725 psi @ 21 gal (50 bar @ 80 L) | |
| Water Pressure (High) | 1883 psi @ 21 gal (130 bar @ 80 L) | |
| Tractor Fit (Holder) | C70 – C270 | C70 – C270 – C992 – S75 – S100 – S130 |

TRENCH AXE

Use this powerful tool to dig trenches for municipal and recreational projects such as installing drainage systems, road construction work and more.

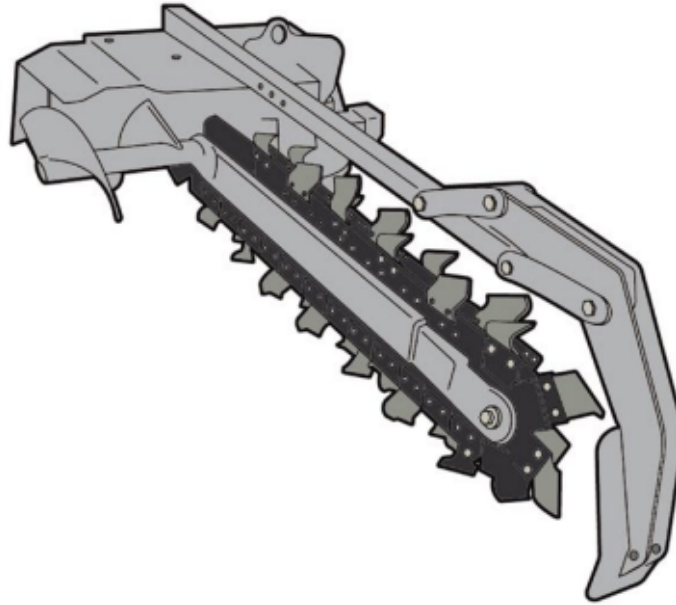

Standard features:

- Side auger
- Heavy duty solid steel nose
- Adjustable chain tension
- Crumb scraper bar

Available options:

- Bullet tooth chain

Compatible Machines:

- TRA-036-01: C992 – S100 – S130

Tractor requirements:

- 3-point hitch external control

| Model | TRA-036-01 |
|------------------------|--------------------------------|
| Trencher Depth | 36" (914 mm) |
| Trencher Width | 4" – 6" (101 mm – 152 mm) |
| Weight | 810 lb (367 kg) |
| Main Shaft Size | 2 – 9/16" Solid Hardened Steel |
| Over Torque Protection | Hydraulic Relief |
| Drive Type | Planetary |
| Power Requirements | 40 HP – 100 HP (30 kW – 74 kW) |
| Tractor Fit (Holder) | C992 – S100 – S130 |

STUMP GRINDER

Easily remove unsightly tree stumps for your landscaping and lawn care needs.

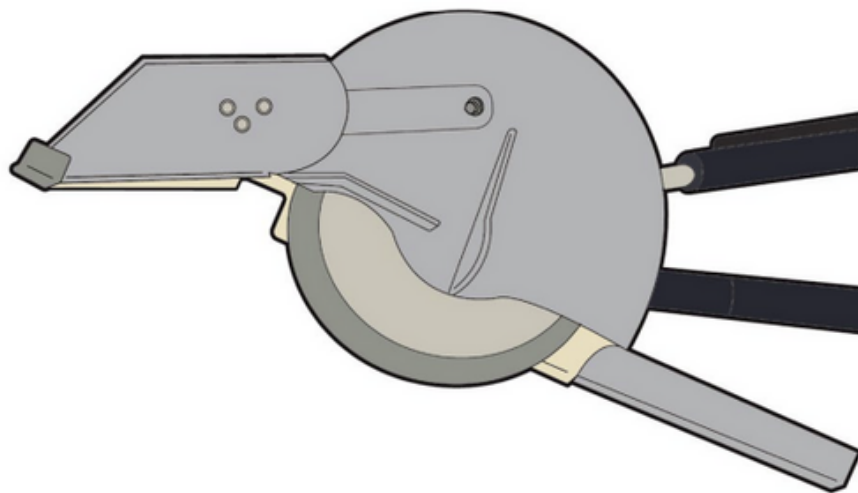

Standard features:

- Flow control cutting pass speed
- Rugged gearbox
- Bolt-on teeth design
- Heavy duty stabilizer base
- Floating deflector

Available options:

- External control

Tractor Requirements:

- Cat II (3-point hitch)

Compatible Machines:

- STG-024-01: C270 – C70 – C992 – S100 – S130

| Model | STG-024-01 |
|----------------------|---------------------------------|
| Length | 49" (1244 mm) |
| Width | 42" (1066 mm) |
| Rotor Size | 24" (609 mm) |
| Number of Teeth | 34 |
| Tooth Construction | S1000 |
| Cutting Wheel Speed | 810 RPM |
| Cutting Height | 18" (457 mm) (Above Ground) |
| Cutting Depth | 8" (203 mm) (Below Ground) |
| Swing Arc | 65° |
| Weight | 624 lb (283 kg) |
| Max. Engine HP | 65 HP (48 kW) |
| Max. PTO HP | 55 HP (41 kW) |
| Power Requirements | 25 HP – 55 HP (18 kW – 41 kW) |
| Tractor Fit (Holder) | C270 – C70 – C992 – S100 – S130 |

WOOD CHIPPER

Conveniently break down tree debris and branches into smaller, manageable pieces.

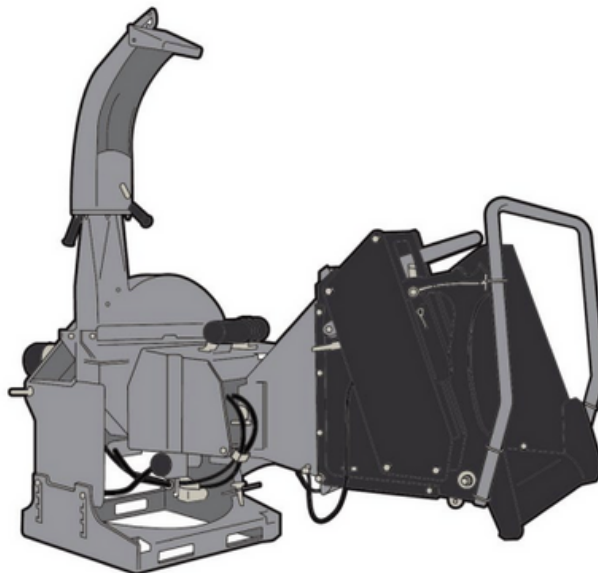

Standard features:

- 360° adjustable chute
- Adjustable ski base
- Dual active rollers
- Fold up feed hopper
- Safety control bar
- Shearbolt protected PTO drivetrain

Available options:

- Reversible rotor knives

Tractor Requirements:

- Cat II – quick hitch compatible

Compatible Machines:

- WCH-005-01: C270 – C70 – C992 – S100 – S130

| | |
|--------------------------|-------------------------------------|
| Model | WCH-005-01 |
| Length (Open) | 80" (2032 mm) |
| Length (Folded) | 62" (1575 mm) |
| Width (Open) | 67" (1702 mm) |
| Width (Folded) | 61" (1549 mm) |
| Height (Open) | 74" (1879 mm) |
| Height (Folded) | 74" (1879 mm) |
| Chipping Capacity | 5" (127 mm) |
| Drive System | PTO Direct Drive |
| Weight | 845 lb (383 kg) |
| Chipper Type | Disc |
| Feed System | Dual Hydraulic Roller Feed |
| Number of Chipper Knives | 4 |
| Discharge Chute Rotation | 360° |
| RPM | 540 – 1000 |
| Hydraulic Flow | 3 gpm – 6 gpm (12 L/min – 23 L/min) |
| Power Requirements | 40 HP – 55 HP (30 kW – 41 kW) |
| Tractor Fit (Holder) | C270 – C70 – C992 – S100 – S130 |

SKIDDING WINCH

Gain heavy duty pulling power for large debris and trees using the skidding winch attachment.

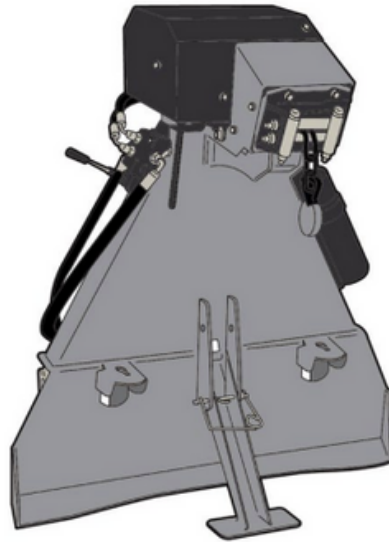

Standard features:

- 2 choker chains
- 2 key hole sliders
- Tow bars
- Trailer hitch
- Removable clutch assembly
- Snatch block pulley system
- Rope controlled brake/clutch system
- Shearbolt protected PTO drivetrain

Available options:

- 2 choker chains
- 2 key hole sliders
- Tow bars
- Trailer hitch
- Removable clutch assembly
- Snatch block pulley system
- Rope controlled brake/clutch system
- Shearbolt protected PTO drivetrain

Tractor Requirements:

- CAT I | CAT II

Compatible Machines:

- SKW-080-01: C270 – C70 – C992 – S100 – S130

| Model | SKW-080-01 |
|----------------------|--|
| Length | 28" (711 mm) |
| Width | 51" (1295 mm) |
| Height | 79" (2006 mm) |
| Pulling Capacity | 11,000 lb (4989 kg) |
| Winch Type | Mechanical Dry Disc Clutch |
| Line Speed | 98 ft/min – 253 ft/min (30 m/min – 77 m/min) |
| Cable Type | Steel |
| Cable Length | 165' (50 m) |
| Cable Diameter | 7/16" (11 mm) |
| Choker Chains | 2 |
| PTO Input Speed | 540 RPM |
| Weight | 796 lb (361 kg) |
| Power Requirements | 50 HP – 90 HP (37 kW – 67 kW) |
| Tractor Fit (Holder) | C270 – C70 – C992 – S100 – S130 |

AND MANY MORE ...

There are attachments available for practically any task. If you require a specific attachment, contact your local Kärcher Municipal representative, or your local dealer. They will be happy to help you find the right tool for your job.

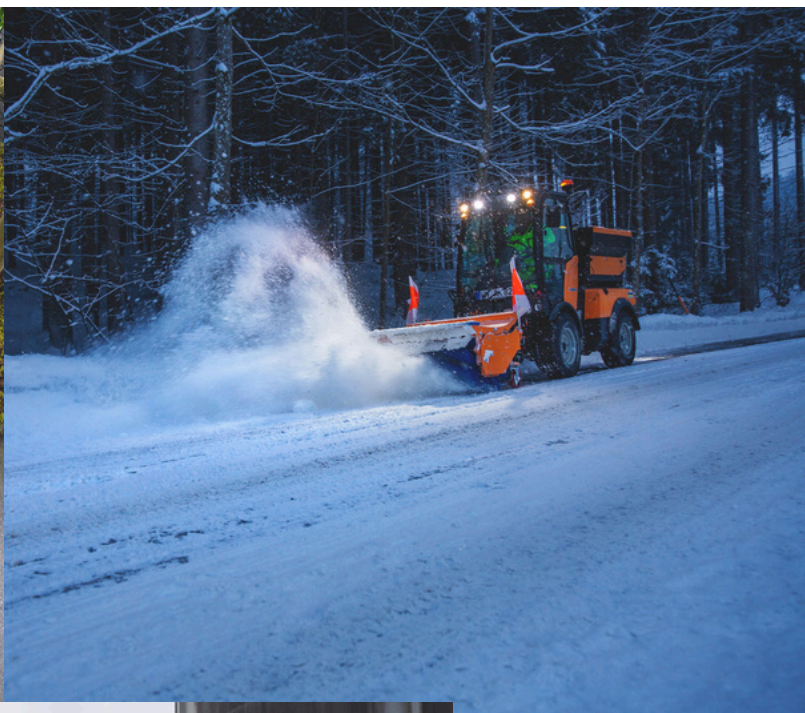
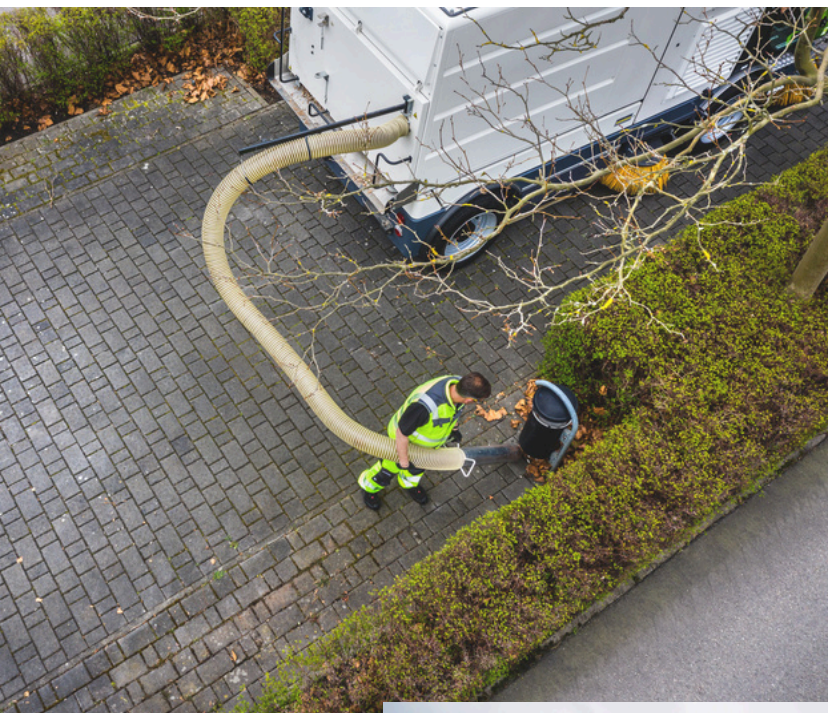

YOUR TEAM DESERVES THE BEST EQUIPMENT FOR THE JOB

Let Americhem be your first call for all of your equipment needs.

THE AMERICHEM DIFFERENCE



- ★ Experienced Equipment Specialists
- ★ Dedicated Divisional Service & Equipment Manager
- ★ Factory Certified Technicians
- ★ Complimentary Training On All Equipment Sales
- ★ Planned Service Programs
- ★ Fleet of Service Vehicles
- ★ Multiple Full-Service Repair Shops

Authorized Service for Leading Manufacturers



 **AMERICHEM**
YOUR PARTNER IN CLEAN
(800) 262-4360 | www.americhem.net



**YOUR
PARTNER IN
Clean™**

Sales - Rentals - Service - Parts
800-262-4360 | www.americhem.net